



Tata Steel International (Australasia) Ltd

Fastenings & Hardware

Stainless Steel















TATA STEEL

SECTION H

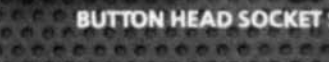



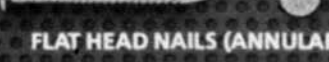





Contents

Fastenings: Nuts, Bolts, Washers, Studding etc	Pages	H1 - H4
Piano Hinge	Page	H5
Butt Hinges	Page	H5



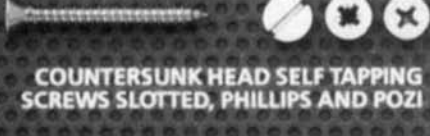











STAINLESS STEEL FASTENINGS

PRODUCT	DIAMETERS	GRADE
 <p>HEXAGON HEAD BOLTS</p>	From M5 to M30 and 1/4" to 1"	304, 316 and SS2343
 <p>HEXAGON HEAD SET SCREWS</p>	From M4 to M24 and 3/16" to 1"	304, 316 and SS2343
 <p>HEXAGON HEAD COACH SCREWS</p>	From M6 to M12	316
 <p>CUP HEAD SQUARE NECK BOLTS</p>	From 1/4" to 1/2" UNC and M6 to M12	304 316
 <p>SOCKET HEAD CAP SCREWS</p>	From M2 to M20, No 2 to 3/4"	304 and 316
 <p>COUNTERSUNK SOCKET SCREWS</p>	From M3 to M16 and No. 6 to 3/8"	304 and 316 304
 <p>BUTTON HEAD SOCKET SCREWS</p>	From M3 to M10 and No. 6 to 3/8"	304
 <p>SOCKET HEAD SET SCREWS (GRUB)</p>	From M3 to M16 and No. 2 to 1/2"	304 and 316
 <p>POST BUTTON HEAD SOCKET SCREWS (SECURITY SCREWS)</p>	From M4 to M8 (Consult for Post CSK)	304
 <p>ENGINEERS STUDS</p>	From M10 to M16 and 3/8" to 5/8"	316
 <p>ALLTHREAD</p>	From M3 to M30 in 1 metre lengths and 3/16" to 1 1/2" in 3 foot lengths	304 and 316
 <p>FLAT HEAD NAILS (ANNULAR RINGS)</p>	From 2.0 mm to 4.0 mm	304
 <p>CHROME MOLYBDENUM STEEL HEXAGON SOCKET KEYS</p>	From M2 to M17 and 1/16" to 5/8"	









STAINLESS STEEL FASTENINGS

PRODUCT	DIAMETERS	GRADE
 <p>ROUND HEAD SLOTTED MACHINE SCREWS</p>	From 1/8" to 3/8"	304 and 316
 <p>CHEESE HEAD SLOTTED MACHINE SCREWS</p>	From M2 to M10 and 12BA to 2BA	304 and 316
 <p>PAN HEAD MACHINE SCREWS SLOTTED AND PHILLIPS</p>	Slotted: From M3 to M6 and No. 2 to No. 10 Phillips: From M2 to M6 and No. 2 to 5/16", 3/16" and 1/4"	304 and 316 304 and 316
 <p>COUNTERSUNK HEAD MACHINE SCREWS SLOTTED AND PHILLIPS</p>	Slotted: From M2 to M12 and No. 2 to No. 10 Phillips: From M2 to M6 and No. 2 to 5/16", 3/16" and 1/4"	304 and 316 304 and 316
 <p>OVAL HEAD (RSD-CSK) SLOTTED MACHINE SCREWS</p>	From M4 to M8 and No. 4 to 1/4"	304
 <p>COUNTERSUNK HEAD SLOTTED WOOD SCREWS</p>	From 4GA to 16GA	316
 <p>COUNTERSUNK HEAD PHILLIPS WOOD SCREWS</p>	From 4GA to 16GA	304
 <p>COUNTERSUNK HEAD SELF TAPPING SCREWS SLOTTED, PHILLIPS AND POZI</p>	Slotted and Phillips: From 4GA to 14GA Slotted and Phillips: From 4GA to 10GA Pozi: From 4GA to 10GA Square drive: From 4GA to 14GA	304 316 304 304
 <p>PAN HEAD SELF TAPPING SCREWS SLOTTED, PHILLIPS AND POZI</p>	Slotted and Phillips: From 4GA to 14Ga Slotted and Phillips: From 4GA to 12GA Pozi: From 4GA to 10GA Square drive: From 4GA to 10GA	304 316 304 304
 <p>"U" DRIVE SCREWS</p>	From 00GA to 10GA	304
 <p>OVAL (RSD-CSK) HEAD ONE-WAY (SECURITY) SELF TAPPING SCREWS</p>	8G and 10G	304

STAINLESS STEEL FASTENINGS

PRODUCT	DIAMETERS	GRADE
 HEXAGON NUTS	From M1 to M48 No. 2 to 1 3/4" and 10BA to 2BA	304 316 and SS2343
 HEXAGON NUTS LEFT-HAND THREAD	From M6 to M16 and 1/4" to 1/2", on request	304
 LOCK NUTS	From M5 to M24 and 1/4" to 1"	304 and 316
 GLENLOCH™ NUTS	From M5 to M20 and 3/16" to 5/8"	304
 NYLON INSERT LOCK NUTS	From M2 to M24 and No. 4 to 1 1/2"	304 and 316
 THIN TYPE NYLON INSERT LOCK NUTS	From No. 6 to 1/2"	304
 ACORN (DOME) NUTS	From M4 to M20 and No. 8 to 5/8" From M6 to M16	304 316
 WING NUTS	From M3 to M16 and 3/16" to 5/8" M20 and 3/4"	316 304
 WELD NUTS	From M4 to M8	304
 FLAT ROUND WASHERS	From M2 to M48 and No. 2 to 2"	304 and 316
 SPRING WASHERS	From M2 to M36 and No. 2 to 1 1/4"	304 and 316
 INTERNAL TOOTH AND EXTERNAL TOOTH LOCK WASHERS	From No. 2 to 5/8" M3 to M16	410 304
 BELLEVILLE WASHERS	From M6 to M20 DIN 2093	304
 CUP WASHERS	From 6GA to 14GA	304
 CRINKLE WASHERS	From M2 to M6	304

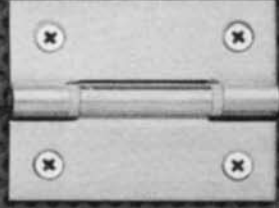
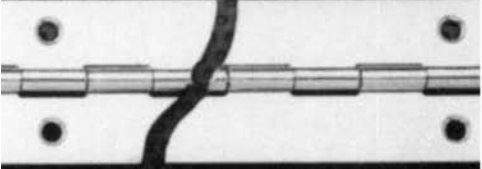
STAINLESS STEEL FASTENINGS

PRODUCT	DIAMETERS	GRADE
 <p>'E' CLIPS, INTERNAL & EXTERNAL CIRCLIPS</p>	Consult	304
 <p>HEX SOCKET PRESSURE PLUGS</p>	From 1/8" to 1/2" BSPT	316
 <p>SPLIT PINS</p>	From M1.0 to M10 and 1/16" to 1/4"	304
 <p>HUMP BACK SPLIT PINS</p>	HP/A and HP/B	316
 <p>GLENLOCH[®] SKEW PROOF ROLLED WAVE SPRING PINS</p>	From M1.5 to M6	420
 <p>ROLLED SPRING PINS</p>	From 1/16" to 1/2"	420
 <p>SPIRAL COILED SPRING PINS</p>	From M1.5 to M12 and 1/16" to 1/2"	302
 <p>BUTT HINGES</p>	From 2" to 4" (Correct wood screws included)	304
 <p>PIANO HINGE</p>	32 mm (1 1/4") Open (1800 mm lengths)	304
 <p>'U' BOLTS 1/4" THREAD SIZE</p>	From 1/2" NB to 3" NB (Consult for tube sizes)	316

ALL CORUS METALS BRANCHES STOCK A COMPREHENSIVE RANGE OF T304 AND T316 STAINLESS STEEL FASTENINGS, METRIC AND IMPERIAL
PLEASE CONTACT YOUR NEAREST BRANCH

PIANO HINGES

HEAVY STAINLESS STEEL

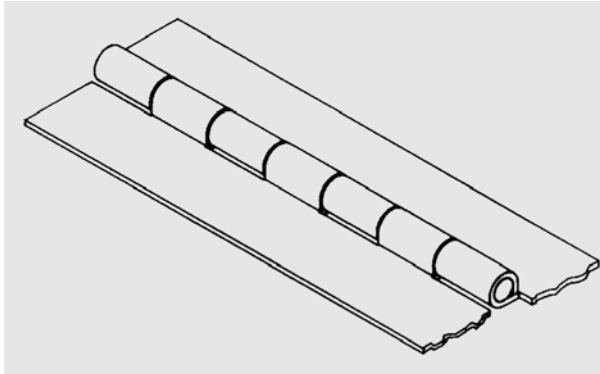

Material

- Type 304 Stainless Steel
- Loose Pin
- Undrilled
- Finish – Unpolished

LENGTH	OPEN WIDTH A	THICKNESS B	
1220 mm	60 mm	1.6 mm	Undrilled
1830 mm	60 mm	1.6 mm	Undrilled

LIGHT STAINLESS STEEL

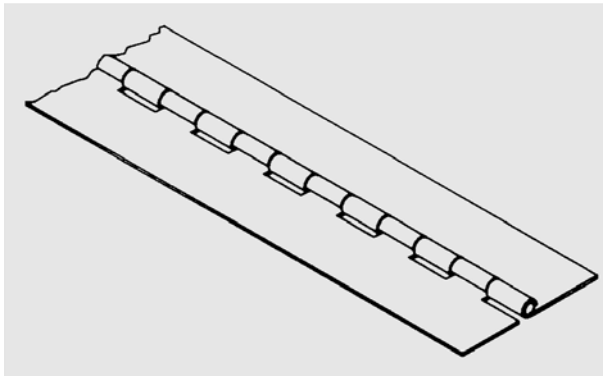

Material

- Type 304 Stainless Steel
- Loose Pin
- Undrilled
- Finish – Unpolished

LENGTH	OPEN WIDTH A	THICKNESS B	
1220 mm	44 mm	0.9 mm	Undrilled

BUTT HINGES

T304

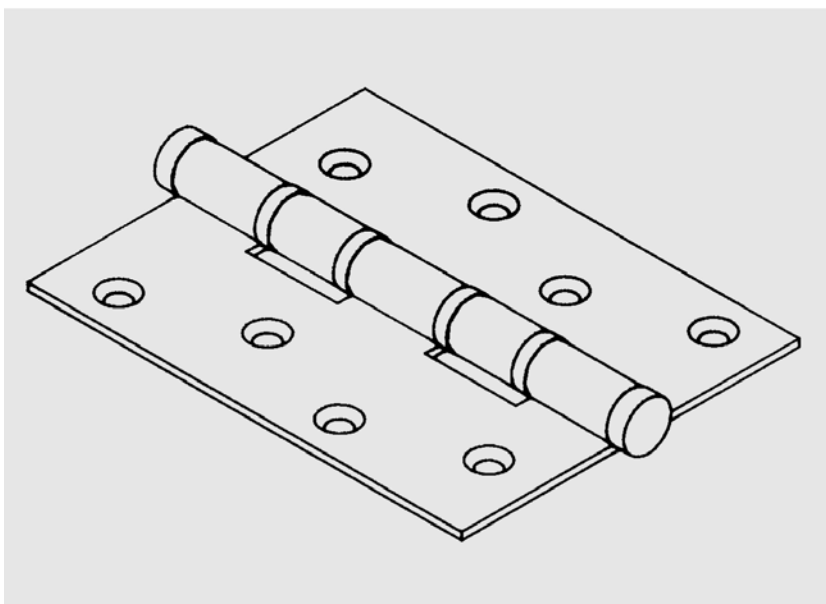

SIZES

2 x 1 1/2 x 1.3 mm with Nylon Rings

3 x 2 x 1.5 mm with Nylon Rings

4 x 3 x 2 mm with Nylon Rings

4 x 4 x 2 mm with Nylon Rings

4 x 4 x 2.5 mm with Nylon Rings

4 x 3 x 2 mm Plain

4 x 4 x 2 mm Plain

4 x 4 x 3 mm Plain



Tata Steel International (Australasia) Ltd

Head Office	7 Bruce Roderick Drive East Tamaki Phone 09 271 1780	PO Box 58880, Botany, Manukau 2163 Fax 09 271 1970 Email: headoffice@tatasteelnz.com
Auckland	7 Bruce Roderick Drive East Tamaki Phone 09 271 1781	PO Box 58880, Botany, Manukau 2163 Fax 09 271 1799 Email: auckland@tatasteelnz.com
Mt Maunganui	18 MacDonald Street Phone 07 574 0095	PO Box 4158, Mt Maunganui South 3149 Fax 07 574 0096 Email: tauranga@tatasteelnz.com
Hamilton	27 Ellis Street, Frankton Phone 07 847 8456	PO Box 1133, Waikato Mail Centre 3240 Fax 07 847 0354 Email: hamilton@tatasteelnz.com
Hastings	807 Warren Street Phone 06 876 3360	PO Box 14043, Mayfair, Hastings 4159 Fax 06 876 3411 Email: hastings@tatasteelnz.com
New Plymouth	Cnr Connett Road & Mustang Drive, Bell Block Phone 06 759 9382	PO Box 3094, Fitzroy New Plymouth 4341 Fax 06 755 7575 Email: newplymouth@tatasteelnz.com
Wellington	141 Hutt Park Road Phone 04 568 5014	PO Box 38065, Lower Hutt 5045 Fax 04 568 6367 Email: wellington@tatasteelnz.com
Nelson	4C Akersten Street Phone 03 548 0603	PO Box 413, Nelson 7040 Fax 03 548 0588 Email: nelson@tatasteelnz.com
Christchurch	200 Maces Road, Bromley Phone 03 381 1994	P O Box 570, Christchurch Mail Centre 8140 Fax 03 381 0606 Email: christchurch@tatasteelnz.com

Toll free: 0800 4 26787

Website: www.tatasteelnz.com

Care has been taken to ensure that the contents of this publication are accurate but Tata Steel International do not accept responsibility for errors or for information which is found to be misleading. Suggestions for or descriptions of the end-use or application of products or methods of working are for information only and the company accepts no liability in respect thereof. Before using products supplied or manufactured by the company the customer should satisfy themselves of their suitability. If further assistance is required the company which has extensive research facilities will often be able to help.